

99.00mm

MODEL: SB770B / SB775B
093-SB770-SB775B-003

Front



English

Sonic Blast Alarm Clock without Projection - Model SB750B Sonic Blast Projection Alarm Clock - Model SB775B

SAFETY INFORMATION

IMPORTANT – Please read these instructions carefully before use and retain for future reference. Only use the supplied or recommended Sonic Alert adaptor to connect the unit.

Warning:

- To prevent fire or shock hazard do not expose this appliance to rain or moisture.
- The ventilation should not be impeded by covering the ventilation openings with items such as, newspaper, table cloth, curtains, etc;
- No naked flame sources, such as lighted candles should be placed on the apparatus.
- It shall not be exposed to dripping or splashing and that no objects filled with liquids shall be placed on the apparatus.
- Do not place the product in closed bookcases or racks without proper ventilation.
- Where the mains/ power plug is used as the disconnect device, the disconnect device shall remain readily operable.

GENERAL DATA

UL listed Power Adaptor: AC100-240V~, 50/60Hz
Power Consumption: Adaptor Output: DC5V ---, 2200mA
USB Charging: Max 1A
Bluetooth: v4.2

CONTROLS & INDICATORS

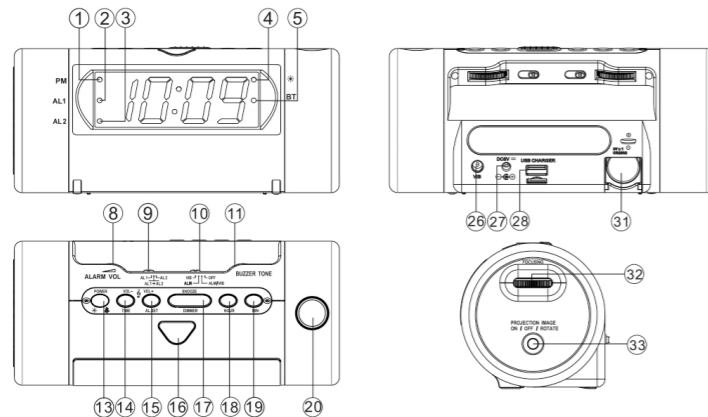

Features

- | | | |
|--|-----------------------------------|---|
| 1) PM Indicator | 14) Time Set / Music Vol - | 26) 5V input |
| 2) Alarm 1 Indicator | 15) Alarm Set / Music Vol + | 27) Power Adaptor input DC5V |
| 3) Alarm 2 Indicator | 16) Alarm Strobe Light | 28) USB Charging Port |
| 4) Strobe Indicator | 17) Snooze / Display Dimmer | 31) Backup Battery Compartment |
| 5) BT Indicator | 18) Hour | 32) Projector Focus (Model SB775B) |
| 8) Alarm Volume Wheel | 19) Min | 33) Projector ON/OFF/ Image Rotate (Model SB775B) |
| 9) Alarm Mode Switch (AL1, AL2, AL1 + AL2) | 20) Projector Lens (Model SB775B) | |
| 10) Strobe Notification Selector | | |
| 11) Buzzer Tone Wheel | | |
| 13) Power / AL. Off / Strobe On/Off | | |

SETUP AND POWER UP THE CLOCK

Unpacking and Power

- 1) Unpack and remove all packing materials from the alarm clock and the component(s).
- 2) Install battery backup by opening the **Battery Cover (31)** and insert the **CR2032** coin size battery (to be purchased separately) observing the polarity and replace the battery compartment cover.

Note: Battery backup is optional. Battery backup maintains clock settings in the event of a power outage. Battery does not power clock features during power outage or without powercord.

- 3) Fully unwind the cord of the DC power cord adapter. Connect the power cord to the **DC5V Power Adaptor Input (27)** on the back of the clock. Plug the power cord directly into an AC wall outlet.

Note: We suggest that you do not use extension cords or power strips to power your clock.

Note: Only use a power cord manufactured for your specific clock model. The use of a third party power adaptor is not recommended, and the use will void the manufacturer's warranty of the clock.

- 4) Attach the SS5V bed shaker, sold separately, to the **Bed Shaker Input (26)** on the back of the clock.

- 5) Place the disk end of the bed shaker either under your pillow, or between the mattress and box spring.

Test Mode

- 1) Press and hold both the **Time (14)** and the **Snooze (17)** buttons for 3 seconds to enter the test mode.
- 2) Slide the **Alarm Notification Selector (10)** to test the alarm volume, light flash, and vibration.
- 3) To exit Test Mode, press the **Power (13)** button briefly, or the system will auto exit after 1 minute of inactivity.

Note: To use Test Mode, exit Bluetooth mode by disconnecting from the Bluetooth speaker by pressing the **Power (13)** button briefly.

OPERATING INSTRUCTIONS

Set the Time

- 1) To adjust the time, first press and hold both the **Time (14)** button and the **Hour (18)** button to advance the hours on the clock and set it to the correct time.
- Note:** When using the 12 hour clock format, PM is indicated by the **Lighted Dot (1)** in the upper left corner of the clock display.
- 2) Then press and hold the **Time (14)** button and **Minute (19)** button to advance the minutes on the clock and set it to the correct time.

Selecting Hours Format (12 Hour or 24 Hour)

- 1) Press and hold the **Hour (18)** button for 6 seconds to enter the hour format selection mode, release the Hour (18) button when the display shows 12H or 24H
- 2) Briefly press the **Hour (18)** button to toggle between the 12H and 24H formats

Set the Alarm Time - Setting Alarm 1

- 1) Slide the **Alarm Selector (9)** to the AL1 position, the alarm indicator AL1 (2) will light up.
- 2) Press and hold the **Alarm Set (15)** button, at the same time press the **Hour (18)** button to advance the hours on the clock and set it to the correct alarm time.

Note: When using the 12 hour clock format, PM is indicated by the **Lighted Dot (1)** in the upper left

- 3) Press and hold the **Alarm Set (15)** button, at the same time press the **Minute (19)** button to advance the minutes on the clock and set it to the correct alarm time.

Setting Alarm 2

Slide the **Alarm Selector (9)** to the AL2 position, the alarm indicator AL2 (2) will light up. Then repeat step 2 and 3 above to set alarm 2 to the correct hour and minute.

Alarm Functions

Enable Alarms:

- 1) To enable Alarm 1, slide the **Alarm Selector (9)** to the AL1 position, and the **Lighted AL1 Dot (2)** will illuminate.
- 2) To enable Alarm 2, slide the **Alarm Selector (9)** to the AL2 position, and the **Lighted AL1 Dot (3)** will illuminate.
- 3) To enable Alarm 1 and Alarm 2, slide the **Alarm Selector (9)** to the AL1+AL2 position, and the dots next to the **Lighted AL1 Dot (2)** and the **Lighted AL2 Dot (3)** will both illuminate.

Alarm Notifications:

- 1) To select sound alert, slide the **Alarm Notification Selector (10)** to ALM
- 2) To select vibration alert, slide the **Alarm Notification Selector (10)** to VIB
- 3) To select both sound and vibration alerts, slide the **Alarm Notification Selector (10)** to ALM+VIB

Note: Bed-shaker must be connected to clock for vibration notification.

Shutting Off the Alarm

Turning off the Alarm Until the Next Day:

- 1) When the alarm is triggered, press the **Power (13)** button until alarm is stopped. AL1, AL2, or AL1 + AL2 indicator light(s) will still be illuminated, and the alarm(s) settings have not changed. Alarm default duration is set to 30 minutes.

Note: The alarm off process for Alarm 1 and Alarm 2 work independent of each other.

Note: The length of the alarm can be changed, see Adjusting Alarm duration.

Shutting Alarm Off Permanently:

- 1) When alarm is triggered, press the **Power (13)** button to stop alarm, then slide the Alarm Notification (10) to the OFF position. AL1, AL2, or AL1 + AL2 indicator light(s) will not be illuminated, and the alarm(s) settings have been changed.

Snooze Operation

- 1) When the alarm notification begins, press the **Snooze/Dimmer (17)** button to stop the alarm temporarily. The default snooze duration is 9 minutes and then the alarm will turn on again. The snooze can be repeated.

Note: The snooze process for Alarm 1 and Alarm 2 work independent of each other.

Note: The length of the snooze can be changed, see Adjusting Snooze duration.

Adjusting the Alarm Duration:

The default alarm duration time is set to 30 minutes; you may adjust the length to between 1 minute and 59 minutes.

To adjust the Alarm Duration:

- 1) Press and hold the **AL Set (15)** button for 6 seconds. The clock display will show the default alarm duration as '30' - release the AL. Set button (15).
- 2) Press the **Hour (18)** button or the **Minute (19)** button to adjust the alarm duration to the desired time, from 1 minute to 59 minutes.
- 3) The clock will automatically return to the normal clock mode when idle for 3 seconds. The new alarm duration will become the new default and will remain in the memory until it is changed.

Adjusting the Snooze Duration:

- 1) Press and hold the **Snooze/Dimmer (17)** button for 3 seconds to enter the setting mode. The clock display will show the default snooze duration as '7' - release the **Snooze/Dimmer (17)** button.
- 2) Press the **Hour (18)** button or the **Minute (19)** button to adjust the snooze duration to the desired time, from 1 minute to 30 minutes.
- 3) The clock will automatically return to the normal clock mode when idle for 3 seconds. The new snooze duration will become the new default and will remain in the memory until it is changed.

Dimmer Adjustment:

- 1) There are 5-levels of brightness for the clock display, press the **Snooze/Dimmer (17)** button once to change the display brightness.
- 2) Continue to press the **Snooze/Dimmer (17)** button until the desired display brightness is achieved.

Note: The dimmer function will not work when the clock is in active snooze mode.

Volume and Tone Adjustment:

- 1) The alarm volume can be changed by rotating the **Volume (8)** wheel to the desired level.
- 2) The alarm tone can be adjusted by rotating the **Tone (11)** wheel to a tone between 800 - 1400 Hz.

Note: Both volume and tone can be adjusted when alarm has been triggered, or during the clock test mode.

210.00 mm

210.00 mm

99.00mm

MODEL: SB770B / SB775B
093-SB770-SB775B-003

Back

USB Charging Function (DC5V, 1A):

This alarm clock is equipped with a dedicated USB 1A charging port. Located on the back of the clock, you can recharge many small electronic or handheld devices (i.e. mobile or smartphones) that use a standard USB charging cable and connection.

To use, connect the USB charging cable that was supplied with your small electronic or handheld devices to the **USB Charging Port (28)** on the back of the clock.

Disconnecting Bluetooth Speaker

Press the **Power (13)** button briefly to turn off the Bluetooth connection, and the light next to BT on the clock face will also turn off.

Bluetooth Speaker Volume Adjustment - Clock

Press and hold the **Volume - (14)** button for 2 seconds to decrease the volume or the **Volume + (15)** button for 2 seconds to increase the volume.

Note: You can also use your smartphone controls to increase and decrease the Bluetooth speaker volume

Model SB775B Only

Clock Projection

- 1) Adjust the projection lens to the wall or ceiling where you want the image of your clock's time to appear by rotating the end of the clock.
- 2) Press the **Projection On/Off (33)** button to turn the projection light on.
- 3) Use the **Focusing Wheel (32)** to adjust the image and reduce any blurring.

Note: To rotate the clock time image, press the Projection On/Off button to flip the image.

SONIC ALERT'S 1 YEAR LIMITED WARRANTY

The Sonic Blast Alarm Clock Models SB750B / SB775B are warranted against manufacturing defects in materials and workmanship for one (1) year from the date of purchase. Within this period, Sonic Alert will repair or replace at our option the SB750B / SB775B without charge for parts and labor. Simply contact our customer service department to obtain an RA (return authorization number) and instructions on how to process your product for return.

Call 248-577-5400 or e-mail customerservice@sonicalert.com. You will need a copy of your receipt to process the return authorization.

Sonic Alert Inc., Troy MI 48083 USA • www.sonicalert.com

Normal function may be disturbed by strong electromagnetic interference. If this is the case, normal function can be resumed by simply resetting the unit following the procedure in the instructions manual. If function does not resume, try moving the unit to another location.



850 Stephenson Highway, Suite 323, Troy, MI 48083
248-577-5400

Made in China

FCC Statement

This device complies with Part 15 of the FCC Rules. Operation is subject to the following two conditions:

- (1) This device may not cause harmful interference.
- (2) This device must accept any interference received, including interference that may cause undesired operation.

Note: The grantee is not responsible for any changes or modifications not expressly approved by the party responsible for compliance. Such modifications could void the user's authority to operate the equipment.

NOTE: This equipment has been tested and found to comply with the limits for a Class B digital device, pursuant to part 15 of the FCC Rules. These limits are designed to provide reasonable protection against harmful interference in a residential installation.

This equipment generates uses and can radiate radio frequency energy and, if not installed and used in accordance with the instructions, may cause harmful interference to radio communications. However, there is no guarantee that interference will not occur in a particular installation. If this equipment does cause harmful interference to radio or television reception, which can be determined by turning the equipment off and on, the user is encouraged to try to correct the interference by one or more of the following measures:

- Reorient or relocate the receiving antenna.
- Increase the separation between the equipment and receiver.
- Connect the equipment into an outlet on a circuit different from that to which the receiver is connected.
- Consult the dealer or an experienced radio/TV technician for help.

This equipment complies with FCC radiation exposure limits set forth for an uncontrolled environment. This equipment should be installed and operated with minimum distance of 20 cm between the radiator and your body.

RF Exposure Information and Statement

This equipment complies with FCC and IC radiation exposure limits set forth for an uncontrolled environment. This equipment should be installed and operated with minimum distance of 20 cm between the radiator and your body. This transmitter must not be co-located or operating in conjunction with any other antenna or transmitter.

FCC+IC Statement

This device complies with part 15 of the FCC rules and RSS-247 of Industry Canada. Operation is subject to the following two conditions:

- (1) this device may not cause harmful interference, and
- (2) this device must accept any interference received, including interference that may cause undesired operation.

Le présent appareil est conforme aux CNR d'Industrie Canada applicables aux appareils radio exempts de licence. L'exploitation est autorisée aux deux conditions suivantes : (1) l'appareil ne doit pas produire de brouillage, et (2) l'utilisateur de l'appareil doit accepter tout brouillage radioélectrique subi, même si le brouillage est susceptible d'en compromettre le fonctionnement.

This Class B digital apparatus complies with Canadian ICES-003. Cet appareil numérique de la classe B est conforme à la norme NMB-003 du Canada.

NOTE: The manufacturer is not responsible for any radio or TV interference caused by unauthorized modifications to this equipment. Such modifications could void the user's authority to operate the equipment.

NOTE: This equipment has been tested and found to comply with the limits for a Class B digital device, pursuant to part 15 of the FCC Rules.

These limits are designed to provide reasonable protection against harmful interference in a residential installation. This equipment generates uses and can radiate radio frequency energy and, if not installed and used in accordance with the instructions, may cause harmful interference to radio communications. However, there is no guarantee that interference will not occur in a particular installation.

If this equipment does cause harmful interference to radio or television reception, which can be determined by turning the equipment off and on, the user is encouraged to try to correct the interference by one or more of the following measures:

- Reorient or relocate the receiving antenna.
- Increase the separation between the equipment and receiver.
- Connect the equipment into an outlet on a circuit different from that to which the receiver is connected.
- Consult the dealer or an experienced radio/TV technician for help
- This device and its antenna(s) must not be co-located or operating in conjunction with any other antenna or transmitter.

210.00 mm

210.00 mm

093-SB775-002